

# SEQUENCE<sup>®</sup> CHAMPION PRIMER

## INSTALLATION AND SERVICE MANUAL

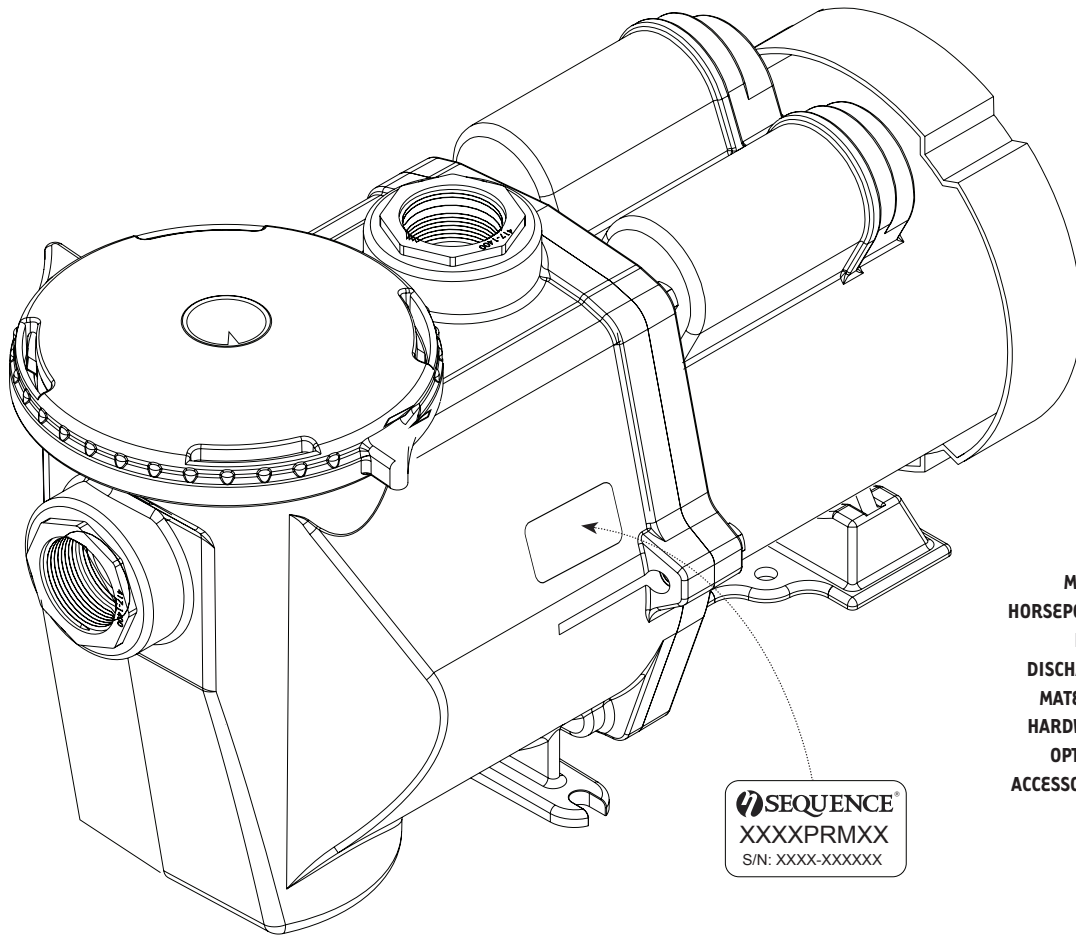

FILL IN FOR FUTURE REFERENCE:

**MODEL:** \_\_\_\_\_  
**SERIAL NUMBER:** \_\_\_\_\_  
**DATE PURCHASED:** \_\_\_\_\_

COMPLETE AND MAIL YOUR WARRANTY REGISTRATION CARD INCLUDED WITH THIS PRODUCT OR FILE ONLINE AT:  
**WWW.MDMINC.COM/PUMP-REGISTRATION**

- TYPE:** STRAIGHT CENTRIFUGAL
- MOTOR:** NEMA 56Y
- HORSEPOWER:** 1/3, 1/2 (1750 RPM) 2 (3450 RPM)
- INLET:** 2" FNPT WITH 2" SLIP ADAPTERS
- DISCHARGE:** 2" & 2 1/2" SLIP ADAPTERS
- MATERIAL:** GLASS-FILLED POLYPROPYLENE
- HARDWARE:** STAINLESS STEEL
- OPTIONS:** SALTWATER SERVICE
- ACCESSORIES:** SWING CHECK VALVES (1.5", 2", 3")

*\*MOTORS ARE SUBJECT TO CHANGE DUE TO AVAILABILITY OR SPECIFICATION REQUIREMENTS.*

CHAMPION PRIMER

HIGH-SPEED CHAMPION PRIMER

Model	3700PRM21	4900PRM21	6600PRM24	6300PRM77	8100PRM81	9300PRM83
INLET	2"	2"	2"	2"	2"	2"
DISCHARGE	2"	2"	2"	2"	2"	2"
MAX FLOW (GPH)	3700	4900	6600	6300	8100	9300
MAX HEAD (FEET)	21'	21'	24'	77'	81'	83"
MAX POWER (WATTS)	228	310	457	1496	1807	2222
MAX CURRENT (AMPS)	2.76 @115V	3.37 @115V	4.61 @115V	8.7 @ 230	9.8 @ 230	11.4 @ 230
VOLTS	115/230	115/230	115/230	230 /115	230 /115	230 /115
MOTOR HP	1/2, 1/3	1/2, 1/3	1/2, 1/3	2	2	2
MOTOR TYPE	56Y	56Y	56Y	56Y	56Y	56Y
MOTOR ENCLOSURE	TEFC	TEFC	TEFC	ODP	ODP	ODP



**Read this manual completely before you install or operate your new pump. This is an external "out-of-pond" pump. It is not submersible. Do not allow this pump to become submerged. Never run dry.**



PROUDLY MADE  
IN THE USA

**Reliable. Efficient.**

© MDM INCORPORATED  
WWW.MDMINC.COM

# SEQUENCE® CHAMPION PRIMER

We congratulate you on your choice of the Sequence® Champion Primer. It has been carefully designed using the advantages of today's technology and carefully constructed to give you the dependability of yesterday. To insure proper performance, we urge you to carefully follow the instructions in this manual. If you have any questions, please call your supplier for assistance or visit [www.mdminc.com/support](http://www.mdminc.com/support).

## INSTALLATION

**Please read carefully. When properly installed the Sequence® Champion Primer will provide dependable trouble-free service.**

1. Locate pump as near the source to be pumped as possible. A flooded suction situation is preferred. This pump is self-priming, however, there must be fluid in the pump for it to function properly. A check valve is recommended for non-flooded suction (Figure 1).
2. Mount motor base to a secure, immobile foundation.
3. Use only plastic fittings on both the intake and discharge ports. Seal pipe connections with Teflon® paste. These fittings should be self-supported and in neutral alignment with each port (i.e. Fittings must not be forced into alignment which may cause premature line failure or damage to the pump volute).
4. Never restrict the intake. Keep both input and discharge lines as free of elbows and valves as possible. Always use pipe of adequate diameter. This will reduce friction losses and maximize output.
5. Before starting pump, the priming pot must be filled with water.

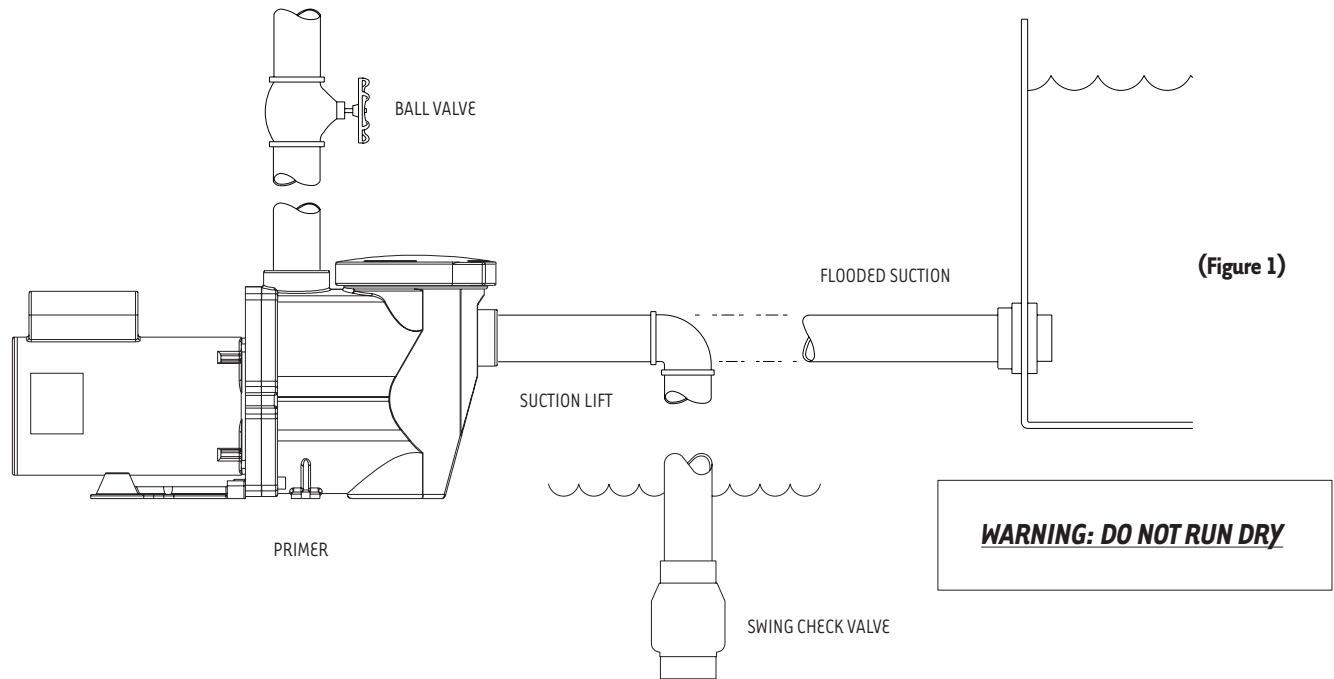

**WARNING: ALWAYS SHUT OFF ELECTRICAL POWER BEFORE INSTALLATION AND / OR SERVICING THIS PUMP.**  
ALL ELECTRICAL WIRING SHOULD MEET STATE AND LOCAL ORDINANCES. IMPROPER WIRING MAY NOT ONLY BE A SAFETY HAZARD BUT MAY PERMANENTLY DAMAGE THE MOTOR AND/OR PUMP. 230V 50HZ MOTORS ARE AVAILABLE. CONTACT YOUR SUPPLIER FOR INFORMATION.



## ELECTRICAL HOOK-UP

1. Check that supply voltages match the motor's requirements.
2. Check motor wiring and connect, according to instructions on motor, to match supply voltage.
3. Power cord should be protected by conduit or by cable and be of proper gauge. It should be no longer than necessary.
4. Power should be drawn directly from a box with circuit breaker protection or with a fused disconnect switch.



PROUDLY MADE  
IN THE USA

*Reliable. Efficient.*

© MDM INCORPORATED  
[WWW.MDMINC.COM](http://WWW.MDMINC.COM)

P.2

# SEQUENCE<sup>®</sup> CHAMPION PRIMER

## PUMP END ASSEMBLY

1. Inspect all pump parts (O-ring, O-ring groove, impeller hub ID, motor shaft, etc.) and clean if necessary.
2. If replacing the seal, apply sealant in bracket bore hole and around seal case according to sealant instructions. We recommend using Gasegacinch<sup>®</sup>. Silicone sealant can also be used.
3. Press seal into bracket while taking care not to damage seal face.
4. Place slinger (rubber washer) over motor shaft and mount bracket to motor.
5. If replacing the seal, carefully lubricate the boot around ceramic piece and press it into the impeller hub making certain that the ceramic is in evenly - the sealing surface should be parallel with the impeller hub.
6. Apply clean water to the carbon-graphite and seal seat sealing surfaces. Do not use silicon lubricants or grease.
7. Mount bracket to motor face.
8. Thread impeller onto shaft and install o-ring and screw. If required, remove motor end-cap and use a screwdriver on the back of motor shaft to prevent shaft rotation while tightening. Replace motor end cap.
9. Place diffuser over impeller and tighten the allen bolts used to hold diffuser in place. Note: Be sure diffuser is in an upright position. (The word "top" appears on the diffuser as an indicator).
10. Seat O-ring on diffuser. Assemble diffuser to bracket with 2 allen screws.
11. Seat O-ring in bracket slot and assemble casing to bracket.
12. Install drain plugs with its O-rings in casing drain holes.

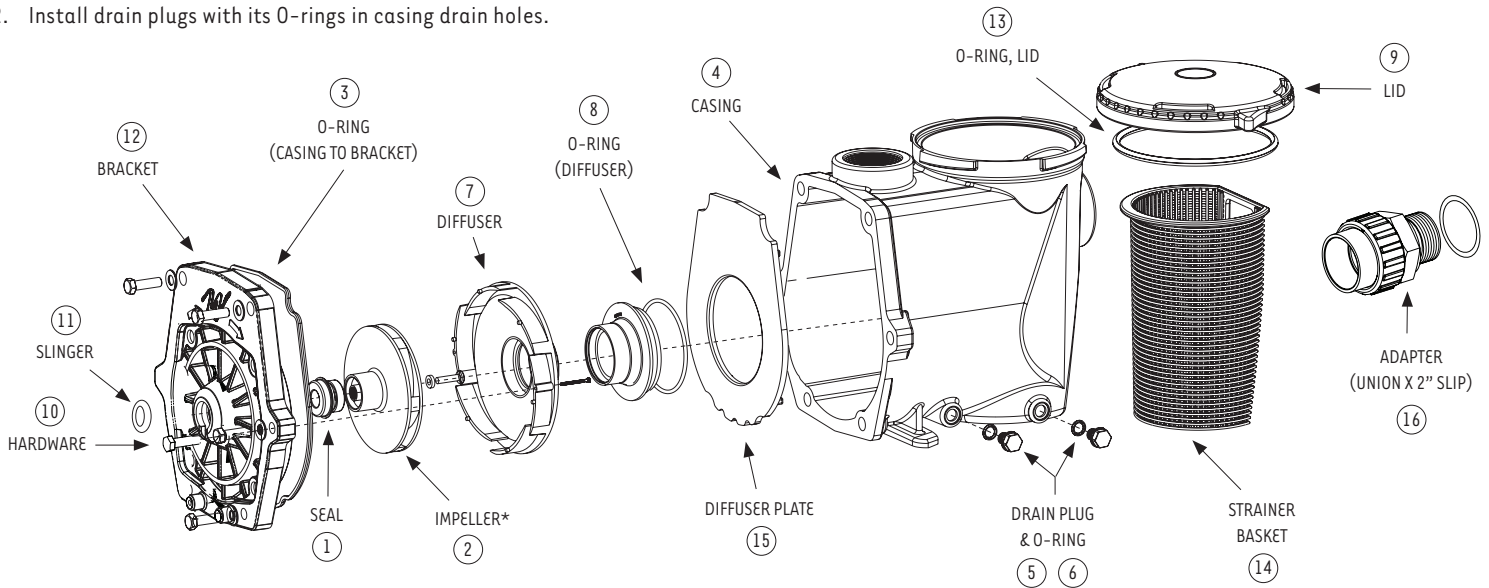

## DISASSEMBLY

1. Shut off power to motor before disconnecting any electrical wiring.
2. Close all necessary valves on inlet and discharge lines and drain the pump by removing both drain plugs. The water will drain faster if you loosen the lid.
3. Disassemble bracket-motor assembly from casing by removing the nuts and bolts. (The casing may be left in-line).
4. Unscrew the two allen bolts and remove diffuser. Diffuser may need to be pried off with a flathead screwdriver.
5. Remove screw and O-ring from front side of impeller. Screw is a left-handed thread and loosens in a clockwise direction.
6. Remove cap covering shaft at back of motor. Unscrew the impeller by twisting counterclockwise while holding the shaft with a large screwdriver to prevent shaft rotation.
7. Remove ceramic piece from impeller (if replacing the seal).
8. Detach bracket from motor.
9. Remove seal from bracket by pressing out from the back (if replacing the seal). Do not dig out from the front.

NO.	DESCRIPTION	P/N
1	SEAL	1000.0414
2	IMPELLER *DEPENDS ON MODEL	CONSULT FACTORY
3	O-RING (CASING TO BRACKET)	8000.061
4	CASING	8000.070
5	DRAIN PLUG	1000.110
6	O-RING (DRAIN PLUG)	805-0112
7	DIFFUSER	8000.120
8	O-RING (DIFFUSER)	8000.121
9	LID	1000.771-L
10	HARDWARE KIT	8000.502
11	SLINGER	1000.010V
12	BRACKET	8000.030
13	O-RING (LID)	1000.771-O
14	STRAINER BASKET	8000.778
15	DIFFUSER PLATE	8000.141
16	ADAPTER, UNION X 2" SLIP	400-5081-2B

# SEQUENCE® CHAMPION PRIMER

## MAINTENANCE

### Lubrication

Motor – Permanently Lubricated ball bearings – no service required.  
 Rotary Seal – Requires no lubrication after assembly.

## WARNING: EYE PROTECTION IS STRONGLY RECOMMENDED

*\*The pump must be drained before servicing or if stored below freezing temperatures. Periodic replacement of seals may be required due to normal carbon wear.*

SYMPTOM	PROBLEM	RESOLUTION
No Flow	Insufficient Prime	Prime system with water and purge all air from suction piping.
		Install check valve.
	Insufficient Power	Verify power supply and connection from panel to pump.
		Verify proper voltage. Some models are dual voltage (115/230).
	Flow Restriction	Ensure valves are open.
		Ensure plumbing is clear, including suction strainers, check valves, etc.
		Verify check valve orientation and direction of permitted flow.
Air leak	Clean out leaves or other debris from basket strainer (if applicable).	
Air leak	Fix air leaks at fittings, connections, strainer basket etc. This typically occurs on the intake side.	
System Incompatibility	Verify hydraulic compatibility: i.e. pump & pipe are sized for the system.	
Low Flow	Air leak	Fix air leaks at fittings, connections, strainer basket etc. This typically occurs on the intake side.
	System Incompatibility	Verify hydraulic compatibility: i.e. pump & pipe are sized for the system.
	Insufficient Power	Verify power supply and connection from panel to pump.
		Verify proper voltage. Some models are dual voltage (115/230).
	Flow Restriction	Ensure valves are open.
		Ensure plumbing is clear, including suction strainers, check valves, etc.
		Clean out leaves or other debris from basket strainer (if applicable).
	Insufficient Prime	Prime system with water and purge all air from suction piping.
	Cavitation	Verify airtight plumbing on the suction plumbing especially fittings.
		Clean out leaves or other debris from basket strainer (if applicable).
Increase pipe size where possible.		
Decrease suction pipe length, reduce the number of elbows, etc.		
	Verify hydraulic compatibility: i.e. pump and pipe are sized for the system.	
Sporadic Operation	Insufficient Power	Verify power supply and connection from panel to pump.
		Verify proper voltage. Some models are dual voltage (115/230).
	Poor Ventilation	Ensure adequate airflow over motor to prevent overheating.
Excessive Noise	Cavitation	Verify airtight plumbing on the suction plumbing especially fittings.
		Clean out leaves or other debris from basket strainer (if applicable).
		Increase pipe size where possible.
		Decrease suction pipe length, reduce the number of elbows, etc.
		Verify hydraulic compatibility: i.e. pump and pipe are sized for the system.
	Insufficient Power	Verify power supply and connection from panel to pump.
		Verify proper voltage. Some models are dual voltage (115/230).
	Flow Restriction	Ensure valves are open.
Ensure plumbing is clear, including suction strainers, check valves, etc.		
	Verify check valve orientation and direction of permitted flow.	



**MDM INCORPORATED**  
 3345 N. Cascade Ave • Colorado Springs, CO • 80907  
 Toll Free Phone (800) 447-8342 • Fax (866) 425-1346  
 www.mdminc.com • sales@mdminc.com

Gasgacinch® is a registered trademark of Porter Manufacturing.

Teflon® is a registered trademark of the Chemours Corporation.

Sequence® is a registered trademark of MDM Incorporated.

Sequence Champion Primer Installation Manual 2020.indd. Adobe Indesign CC. Updated 3/03/20.



PROUDLY MADE  
 IN THE USA

**Reliable. Efficient.**

© MDM INCORPORATED  
 WWW.MDMINC.COM

P.4